

## SECTION 6

### STORM DRAINAGE (SD)

- 6-1 GENERAL** - Drainage improvements include, but are not limited to, culverts, drainage inlets, lined channels, manholes, outlet and inlet structures, and storm drain pipe. These improvements shall be installed in accordance with the approved Improvement Plans, these Construction Standards and the latest edition of the State Standard Specifications. These Standards shall apply to the public right of way and easements.
- 6-2 CONSTRUCTION STAKING** - the Developer for all drainage improvements shall provide Construction staking. Such staking shall provide the station and offset, as well as the cut to the nearest hundredth of a foot (0.01 feet). Stakes shall be provided at a minimum of every fifty (50) feet in tangent sections and every twenty-five (25) feet in curved sections. Cut sheets shall be on site and shall be furnished to the Public Works Inspector upon request.
- 6-3 DRAINAGE INLET INSTALLATION** - Drainage inlets shall conform to the provisions and details of the State Standard Specifications and Standard Plans, and these Construction Standards. The interior of the drainage inlet shall have a troweled finish; rock pockets shall be grouted and brushed; exposed top surfaces shall have a Class I Surface Finish. Within all City streets and easements and within all commercial sites and private residential subdivisions, a City approved fish stamp, "No Dumping, Drains to Creek," shall be placed adjacent to all drainage inlets. If the storm drain system is active and open to discharges, then immediately following installation, all storm drain inlets shall be protected with sediment control protection until construction no longer poses a risk of sediment discharges.
- 6-4 MANHOLE INSTALLATION -**
- A. Bases -**
1. Precast - Precast bases shall be placed on a foundation of ½-inch minus crushed rock, a minimum of 4 inches thick, compacted to 90 percent relative compaction. Elevation differentials of inlets and outlets shall conform to the approved improvement plans. Openings in the base shall align true with all inlet and outlet pipes. Stub-out or couplings provided in precast bases shall be of the same material as the pipe to which they connect, unless otherwise approved by the Public Works Inspector.
  2. Cast-in-Place Base - The cast-in-place base portion shall not be placed higher than six (6) inches above the outside tops of the main incoming and outgoing pipes.

The wall thicknesses for the top of the cast-in-place base sections shall conform to the following table:

<u>Manhole Diameter</u>	<u>Minimum Wall Thickness</u>
48"	5"
60"	6"
72"	7"
84"	8"
96"	9"

Inside diameters of cast-in-place base portions shall equal the inside diameter of the manhole specified. Standard precast manhole riser sections and/or cones shall be placed above the cast-in-place section to bring the manhole rim to finish grade. Upon pouring the concrete base, the top surface of the cast in place base barrel shall be stamped with a rigid impression ring in order to match it up with the above, precast barrel section. As an alternate, a maximum one-foot barrel section may be stacked when it is determined that the concrete for the base is adequately stiff. A 24 hour minimum curing time is required before manhole stacking is allowed.

All inlets and outlets with a 30 inch inside diameter or smaller, connecting to existing manholes, shall be core bored.

Concrete, in the cast-in-place portion, shall be placed against undisturbed earth or upon a base of crushed rock or sand. All loose material shall be removed from the excavation prior to installation.

- B. Cones** - Cone tops shall be placed within 7 to 18 inches of final street grade. Where depth is insufficient for cones, flat slab tops shall be used. Lifting rings in precast cones shall be plugged with dry packed mortar.
- C. Joints** - Joints in precast manhole sections shall be made with either mortar or plastic sealing compound.
- 1. Mortar Application** - All joint surfaces and the face of the manhole base shall be thoroughly cleaned and wetted before applying mortar. Both the inside and outside of mortared joints shall be plastered with mortar, and the inside surfaces brushed to a smooth finish with a wet brush. Special precautions shall be taken to ensure that the entire joint space is filled with mortar and is watertight.
  - 2. Plastic Sealing Compound Application** - All joint surfaces and the face of the manhole base shall be thoroughly cleaned before applying plastic sealing compound. The sealing compound shall be protected from dirt during application. Ends of the compound shall be joined end-to-end and not joined by overlapping. Sufficient compound shall be used to cause a visual "squeeze-out" of the compound material when adjacent sections are seated. Squeeze-out material on the inside of the manhole shall be neatly trimmed flush with the inside surface.
- D. Connections** - Pipe connections to drainage manholes shall be made so that the pipe is flush with the inside face of the manhole. These connections shall be finished so that entrances are smooth. Unless the manhole is cast around the pipe, connections shall be made with dry packed cement mortar. Pipe connections shall not be made into the cone section of the manhole unless shown on the approved plans.
- E. Grade Rings** - Grade adjustments shall be made using precast grade rings. Precast rings shall be a minimum of one (1) inch in height. The total height of the grade rings, frame, and cover casting shall not exceed eighteen (18) inches.
- F. Frames and Covers** - The tops of frames and covers shall be set flush with finish grade pavement in the street, six inches above finish grade in landscape areas, and 12 inches in unimproved, isolated areas, unless otherwise shown on the approved plans. Covers outside of paved area shall be bolt down. Per the "Standard Precast Drainage Manhole" detail, a 12- inch deep by 12- inch wide

concrete collar shall be placed around the casting, covered by two inches of asphalt concrete paving in street areas. All joints between the frame, grade rings, dome, barrels and base shall be sealed with non-shrink mortar, or an approved plastic sealing material. Inside the manhole, all joints where the sealing material is not flush with the inside wall shall be grouted with non-shrink mortar and finished/wet-brushed.

**G. Adjusting Existing Manhole Frames** - The frame shall be supported above the grade ring or dome by spacers. After the concrete collar is poured, any space between the frame and grade ring and dome shall be filled with non-shrink mortar, and the inside wall of the riser finished/wet-brushed.

**H. Manhole Backfill** - Structural backfill shall be Class 2 Aggregate Base to a minimum of five (5) feet surrounding all sewer manholes, extending from the pipe bedding zone to the top of the overlying asphalt concrete pavement. Backfill shall be installed per the requirements of the "Streets" section of these Construction Standards.

**6-5 JUNCTION BOXES / VAULTS** - Manholes shall not exceed 96 inches in diameter. Where the number of pipes and/or pipe diameters requires a larger structure than a 96 inch diameter manhole, junction boxes or vaults are required. Vaults shall be designed by a registered Civil Engineer. Shop drawings shall be submitted and approved by the City Engineer.

**6-6 AREA DRAINS** - Area drains may be used for the collection of stormwater in landscaped areas. Area drains shall conform to the details shown on the approved plans or as approved by the City Engineer.

**6-7 TRENCHING AND BACKFILL** - Construction of drainage pipes and appurtenances shall be performed to the lines and grades shown on the approved project plans, as specified in the Streets section of these Construction Standards, and in conformance with the following requirements:

**A. Excavation** - Pipeline excavations shall be open-cut trenches, unless otherwise specified on the approved improvement plans, with vertical sides to the pipe crown as specified on the "Utility Trench Bedding, Backfill and Paving" detail. Excavations shall conform to all applicable Federal and State safety requirements. All work shall be conducted in such a manner as to prevent damage to new and existing facilities, or adjoining property.

**B. Pipe Support** - Pipes shall be placed on a firm bed of imported granular material conforming to the "Utility Trench Bedding, Backfill and Paving" detail. Bedding shall provide uniform and continuous support along the barrel of the pipe. The minimum depth of bedding material shall be provided under the bell. Blocking of the pipe is not permitted. Loose material shall be removed from the trench bottom and replaced with imported material.

**C. Trench Backfill and Compaction** - Initial backfill material shall be placed immediately after pipe joints have been completed, inspected and passed by the Public Works Inspector. The material shall be carefully placed, consolidated around the pipe zone and shall be brought up evenly on both sides. Sufficient care shall be taken to prevent movement or damage to the pipe during shovel slicing. Shovel slicing shall be witnessed by the Public Works Inspector prior to shading the pipe.

Trench backfill shall be placed and compacted in accordance with the "Streets" section of these Construction Standards. Compaction equipment shall not make direct contact with the pipe.

**6-8 PIPE INSTALLATION** - Drainage pipe shall be installed in accordance with the following provisions:

**A. Laying Pipe** - Corrugated dual wall HDPE pipe shall be the preferred pipe material for storm drain conduit. The pipe shall be laid upstream with the bell end of the pipe placed upstream. The interior of the pipe shall be kept clean as the work progresses. There shall not be a change in pipe material between storm drain structures.

1. Laying and backfill shall conform to State Standard Specifications, the manufacturer's recommendations, ASTM D- 2321 and the Standard Details, with the following modifications:

- a. Due to the lightweight characteristic of the pipe, extreme care shall be taken to avoid displacing the pipe during the backfilling operation. Following placement of the pipe on the required bedding and to the required grade, the pipe shall be stabilized in place with ballast. At a minimum, this shall be accomplished by loading the pipe down slowly and carefully with small piles of embedment material to a minimum of one foot above the pipe on each joint and midway on each length. The pipe shall be kept centered in the trench during this operation. Every precaution shall be taken to avoid flooding the trench prior to placing backfill. The Public Works Inspector may require dewatering of the trench to confirm pipe grade, and to retest the integrity of the pipe following trench flooding.
- b. The trench shall be backfilled with embedment material 6 to 12 inches above the pipe, prior to continuing with the trench backfill.
- c. Pipe material shall not change between manhole structures or between the last structure and the discharge/inlet opening.
- d. No pipe, conduit or any other appurtenance shall be located within any existing or newly constructed storm drainpipe or culvert. Each run of storm drain pipe and culvert shall be 100% clear and unobstructed the total length.

**B. HDPE Pipe Testing** - A mandrel test shall be conducted following completion of subgrade processing and compaction for curb, gutter and sidewalk, and asphalt concrete pavement. Placement of curb, gutter and sidewalk, and asphalt concrete pavement (and related aggregate base) shall not occur until the Public Works Inspector has approved the mandrel test. The Public Works Inspector shall be present through the duration of the mandrel testing.

The allowable deflection (reduction in vertical inside diameter) for all non-rigid pipes shall be 7.5% maximum. The deflection shall be tested by pulling a mandrel, which is 92.5% of the inside pipe diameter, through all installed pipe. The mandrel shall be the "go/no-go" type and shall be pulled per the manufacturer's recommendations without mechanical assistance. Prior to the mandrel test, the pipe shall be thoroughly flushed and cleaned, (See Subsection "J" below). Obstacles in the pipe shall be removed. At each location in which the mandrel cannot pass, the cause shall be ascertained. If it is found the deflection exceeds 7.5%, or that a gasket has been mis-installed, or that the pipe has been damaged due to construction activities, then the respective section of pipe shall be repaired and retested. Pipe section repair operations may require rebedding pipe, replacing pipe, or both as needed to properly repair pipe sections. Watertight repair couplings shall be used in repair. A passing mandrel retest is required.

At the Contractor's discretion, any sections of non-rigid pipe, not passing the mandrel test, may be televised to evaluate the problem.

- C. Pipe Laying Tolerances** - The pipes shall be laid true to line and grade with allowed tolerances of 0.05 foot above or below the design grade and 0.15 foot left or right of the design alignment.
- D. Reinforced Concrete Pipe** - Reinforced concrete pipe shall conform to provisions of the “Reinforced Concrete Pipe” section of the State Standard Specifications. Where excavations for other utilities undermine installed concrete pipe, that excavation shall be backfilled to the spring line of the cast-in-pipe with two sack slurry per these Standards.
- E. CMP Pipe** - CMP pipe may be allowed on a case by case basis upon approval of the City Engineer. CMP pipe shall conform to the provisions of the “Corrugated Metal Pipe” section of the State Standard Specifications.
- F. Pavement Cutting and Repaving** - When the trench line is in an existing pavement area, the pavement shall be sawed or scored and broken ahead of trenching operations in accordance with the “Streets” section of these Construction Standards.
- G. Cleaning of Storm Drain System** - The storm drain system shall be cleaned to the satisfaction of the Public Works Inspector upon completion. If flushing is utilized, then the discharge shall not be routed into the existing City system. The downstream manhole shall be plugged and the discharge fluid shall be disposed of in a manner satisfactory to the Public Works Inspector. Flushing shall comply with requirements of these Standards.

**6-9 CHANNEL LINING INSTALLATIONS** - Channel lining installations shall conform to the “Lined Channel Section” detail and to the following specifications:

- A. Surface Preparation** - The surfaces of the areas to be lined shall be evenly graded to the lines, and grade, and sections as indicated on the approved plans. The surfaces shall be moistened thoroughly to prevent moisture from being drawn from the freshly placed lining.

All surfaces on which lining is to be placed shall be free from water, mud and debris and shall be firm enough to prevent contamination of the fresh lining by earth or other foreign material. Prior to placing any lining, the Contractor shall verify line and grade of the excavated channel.

- B. Reinforcement** - Welded wire fabric shall be embedded in the concrete so that it will be a minimum of one (1) inch clear from either face of the concrete, unless otherwise noted.
- C. Joints** - Construction joints shall be square and edged with a ¼ inch radius-edging tool. The edge shall be thoroughly wetted before the next section of lining is placed. Construction joints shall be constructed whenever the operation is halted for a period exceeding 30 minutes. Welded wire fabric reinforcing shall extend through the construction joint.

Transverse deep tool joints deep tool joints shall be constructed at 10- foot intervals. The aggregate shall be separated with the joint tool a minimum of two inches deep. Immediately following application of the deep tool, a 1/4- inch grooving tool shall be applied to the surface to seal the joint.

- D. Weep Holes** - On channels with side lining extending more than 18 inches vertically above the channel toe, weep holes shall be constructed at intervals of ten (10) feet, midway between contraction joints on each side of the channel. The weep hole elevation shall be twelve (12) inches above the adjacent toe of slope.

The holes shall be backed by a minimum of 1 cubic foot of aggregate material tied in a burlap bag.

The aggregate shall extend at least 6 inches above and below and to each side of the weep hole, and at least 10 inches into the side slope. The side and back of the burlap sack shall be protected from being coated by mortar or concrete during the lining placing operation.

On the day following the lining placement, each weep hole shall be rodded to assure it has not been blocked. The weep hole shall then be cut to fit the channel slope.

- E. Cutoff Walls** - Cutoff walls shall be constructed around the perimeter at each end of the channel lining and at all locations where the new lining meets structures or existing lining, and at all other locations shown on the approved plans. The cutoff walls shall be a minimum of six (6) inches thick and eighteen (18) inches in depth, as measured from the surface of the lining. The welded wire fabric shall be bent down into the cutoff walls.

## **6-10 MATERIALS -**

- A. Backfill Material** - All drainpipe backfill material shall conform to “Utility Trench Bedding, Backfill and Paving” detail.

- B. Drainage Inlets** - All drainage inlets shall conform to the State Standard Plans and the following.

1. Drainage inlets located in gutter pans shall be Caltrans Type G5, or as approved by the City Engineer.
2. All drainage inlets shall be equipped with bicycle proof grates, regardless of inlet location.
3. Inlets shall have plastic steps when grate to floor height is greater than three (3) feet.

- C. Manholes** - All precast manhole barrels, risers, cones, flat tops and grade rings shall conform to ASTM Designation C478 and the Standard Details.

1. Bases - Bases shall be either precast or cast-in-place. Cast-in-place bases shall contain not less than 6 sacks of cementitious material per cubic yard. Cementitious material shall be “Type II Modified” Portland Cement Concrete and mineral admixture, or as otherwise approved by the City Engineer, and shall conform to the provisions in Section 90 of the State Standard Specifications..

Slump shall not exceed 4 inches as determined by the slump cone method of ASTM Designation C143 or an equivalent slump as determined by Test Method No. California 533.

2. Barrels - Manhole barrels shall conform to dimensions of Teichert Precast Products or Jensen Precast or approved equal.
3. Cones - Cones shall be eccentric when rim to floor height is less than three (3) feet, unless otherwise shown on the approved improvement plans. Eccentric cones shall be used, and plastic steps installed, when rim to floor height is greater than three (3) feet. Cones shall be Teichert Precast Products or Jensen Precast, or approved equal.

4. Joints/Mortar - Joints shall be made with either non-shrinking mortar or with a plastic sealing compound conforming to Federal Specification SS- S- 002- 10. Mortar shall consist of one cubic foot of Portland Cement Concrete to two cubic feet of concrete sand.
5. Manhole Frames and Covers - All manhole frames and covers shall be of cast iron or ductile iron and conform to ASTM Designation A48, C478 or ASTM A536 for Ductile Iron or, Class 30 and shall be the following or approved equal for the indicated size and application:
  - a. 24 inch frame and cover: D&L Supply #A-1021 (standard 6-5/8 inch high) or South Bay Foundry #D1920; "D" shall be embossed in center.
  - b. 36 inch frame and cover: D&L Supply #A-1462 or South Bay Foundry #D1907; "D" shall be embossed in center.
  - c. 24 inch frame and slotted cover: D&L Supply #C- 2660 (#A-1021 with slotted cover), or South Bay Foundry #1920 (specify slotted cover).
  - d. Short 24 inch frames and covers: D&L Supply #A-1022 (5 inch) and #A-1023 (3 inch); Southbay Foundry #1922 (5 inch) and #1923 (3 inch).
  - e. Rexus Manhole Cover: Saint-Gobain Pam, CDRU60EHDRA, 24-inch round lightweight hinged, ductile iron manhole cover.

Note: Covers for all 24-inch frames are interchangeable.

**D. Storm Drain Pipe** - Storm drain pipe shall conform to the following:

1. High Density Polyethylene Pipe (HDPE) - HDPE shall be Type "S", conforming to Section 64 of the State Standard Specifications. Joint connections shall be water tight, rubber ring gasketed.

HDPE shall be Hancor Sure-Lok ST or Hi-Q, ADS, Inc. (N-12 WT (watertight)), or approved equal.

2. Reinforced Concrete Pipe (RCP) - RCP shall conform to ASTM Designation C76 for Class I, II, III, IV or V. The class of pipe shall be based on the designation conforming to the approved plans.

Joints for RCP shall be bell and spigot with rubber gasket. The gasket shall conform to Section 65 of the State Standard Specifications.

**E. Stormwater Treatment Devices** - Devices to be used shall provide hydrodynamic separation of oil, fine sediment and debris from stormwater. Treatment devices must provide for easy inspection and unobstructed maintenance. Approved units include the following:

1. Contech - Vortechs, CDS, Vortsentry, Vortsentry HS.
2. Stormceptor - STC Systems

**F. Slurry Cement Backfill** - Slurry cement backfill shall conform to the requirements of Section 19 of the State Standard Specifications.

**G. Lined Channels** - All lined channels shall conform to Standard Details and the following:

1. Air Blown Mortar - Air blown mortar shall conform to provisions in Section 53 of the State Standard Specifications.
2. Concrete - Concrete shall be either shall be a 6 sack mix with “Type II Modified” Portland Cement Concrete and mineral admixture, sacked concrete, or doweled and sacked concrete. The minimum weight of sacked concrete shall be 60 pounds per sack.
3. Curing Compound - Curing Compound shall conform to provisions in Section 90- 7.01B of the State Standard Specifications.
4. Grouted Cobbles - Grouted cobbles shall be set in six inches of shall be a 6- sack mix with “Type II Modified” Portland Cement Concrete and mineral admixture. The top surface of the concrete shall be flush with adjacent finish grade. Cobbles shall be four to ten inches in size, with 1/3 exposed above the concrete surface, per State Standard Specifications. Base for concrete shall be undisturbed native soil. If the soil is disturbed or undercut, it shall be processed to 90% relative compaction.
5. Weep Holes - All weep holes shall be two (2) inches in diameter and made of galvanized steel pipe, schedule 40 or better; PVC pipe, schedule 40 or better; or, ABS pipe, schedule 40 or greater.
6. Welded Wire Fabric - Welded wire fabric shall be sized per the plans and shall conform to ASTM Designation A 185.

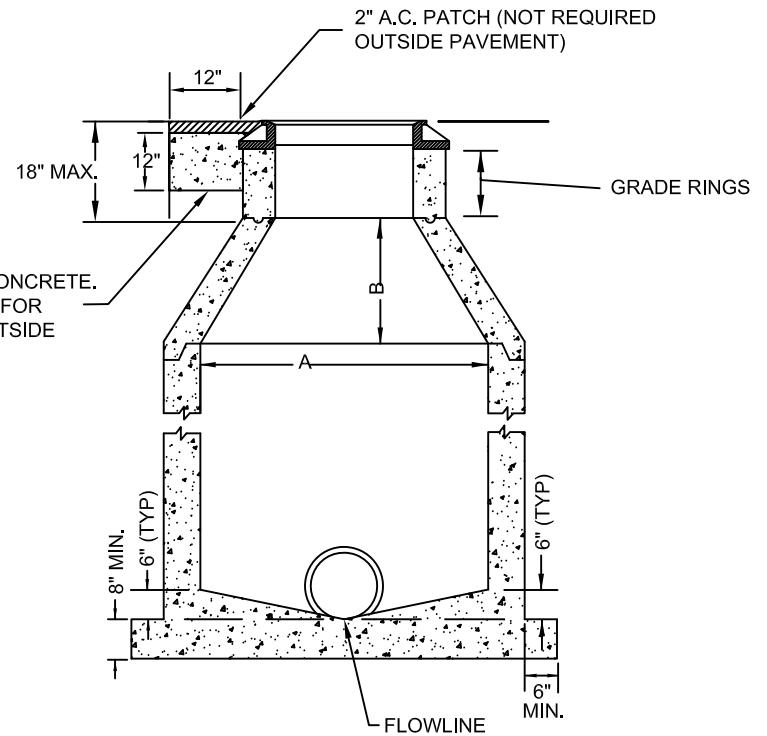

TABLE OF DIMENSIONS

A	B	T MIN.
48"	18"	6"
60"	30"	8"
72"	42"	8"
84"	54"	12"
96"	12" (FLAT)	12"

DIMENSION "B" IS A MINIMUM DIMENSION AND MAY BE GREATER IF DEPTH PERMITS. RISER SECTIONS, CONES, AND ADJUSTING RINGS SHALL CONFORM TO ASTM DESIGNATION C-478

CLASS A, 6 SACK NON-REINFORCED CONCRETE. SEE SECTION 101-4F FOR CASTING HEIGHT OUTSIDE PAVEMENT.



**NOTES**

1. ECCENTRIC CONES SHALL BE USED WHERE SPECIFIED ON THE PLANS.
2. JOINT MAY BE EITHER KEYED OR TONGUE AND GROOVE.
3. SEE SECTION 6-10 FOR JOINT COMPOUND. (ALL MANHOLE JOINTS)
4. TOP OF FRAME SHALL BE 1/8 INCH BELOW ADJACENT PAVEMENT
5. 0.20 FOOT MINIMUM FALL THROUGH MANHOLE.
6. O.D. OF PIPE SHALL NOT EXCEED I.D. OF ITS MANHOLE BARREL
7. IRON TO BE SET 1/4 INCH BELOW FINISHED GRADE

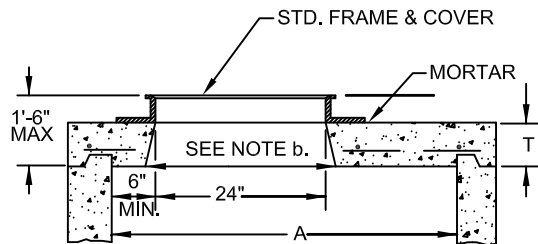
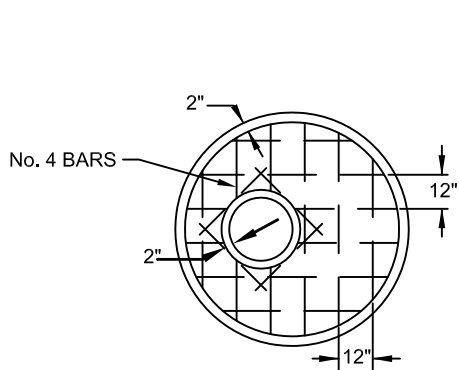

**NOTES**

1. A FLAT TOP SLAB SHALL BE USED WHEN A SHALLOW LINE DOES NOT PERMIT USE OF A TAPERED DOME.
2. IF THE BOTTOM, INSIDE DIAMETER OF THE FLAT TOP OPENING IS 28 INCHES OR MORE, THE THICKNESS OF THE SLAB MAY BE DISREGARDED IN COMPUTING THE MAXIMUM 18 INCH HEIGHT OF THE OPENING.

**FLAT TOP SLAB**

	PUBLIC WORKS DEPARTMENT ENGINEERING DIVISION	
	<b>STANDARD PRECAST DRAINAGE MANHOLE</b>	
APPROVED BY:		
	PUBLIC WORKS DIRECTOR / CITY ENGINEER	
SCALE: NONE	DRAWN BY: TMT	DATE: FEB 25, 2014
		<b>DR - 1</b>

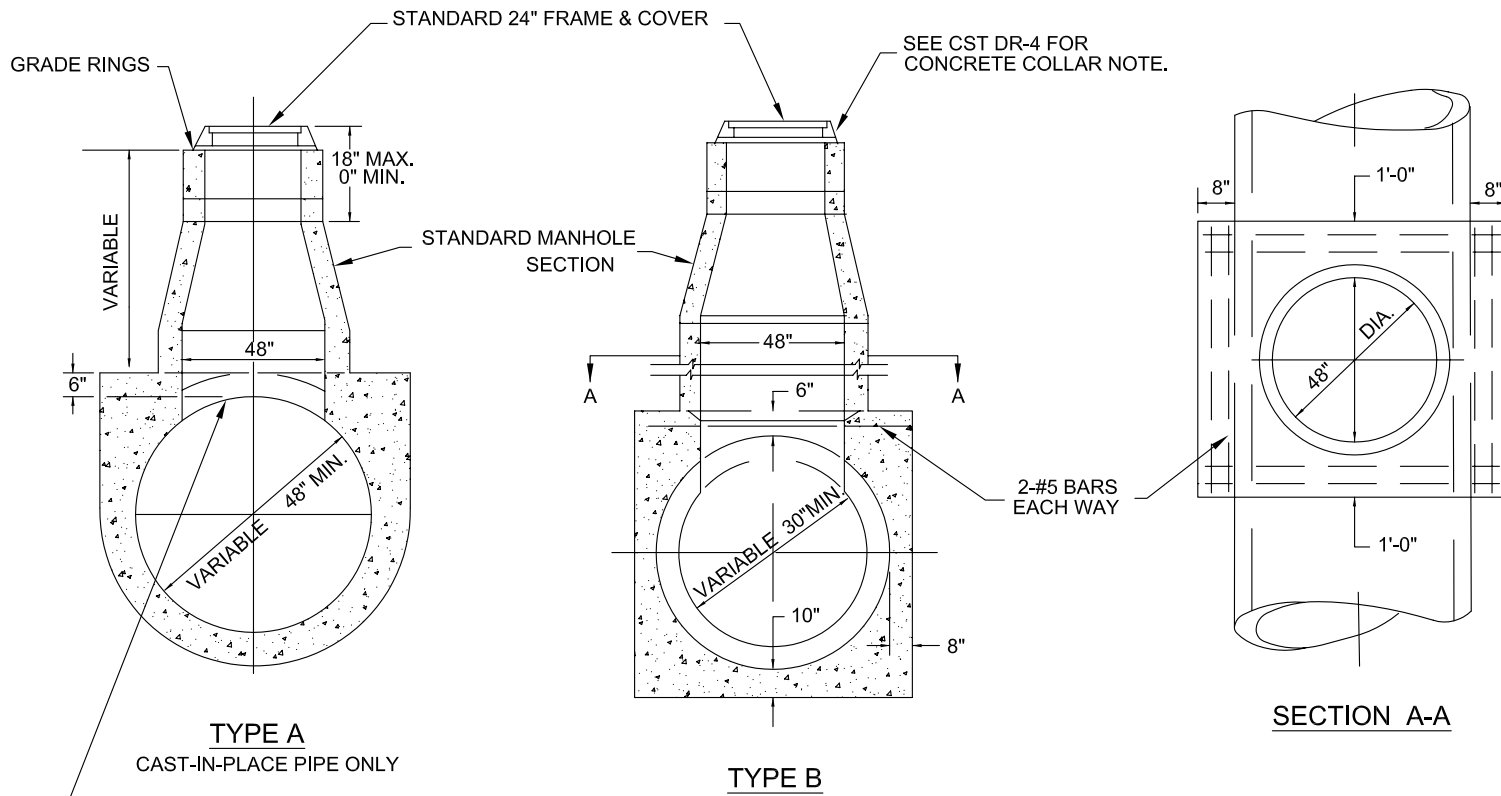



**NOTES:**

1. REMOVE CONCRETE IN MANHOLE OPENING AND CONSTRUCTION RISER BASE WHILE CONCRETE IS STILL FRESH.
2. PLACE RISER SECTION AFTER CONCRETE HAS SET.

**NOTES**

1. ALL PIPE OTHER THAN CAST-IN-PLACE PIPE.
2. CAST-IN-PLACE PIPE LESS THAN 48" DIA.

	PUBLIC WORKS DEPARTMENT ENGINEERING DIVISION	
	<b>TYPE A &amp; B          SADDLE MANHOLE</b>	
APPROVED BY:  PUBLIC WORKS DIRECTOR / CITY ENGINEER		
SCALE: NONE	DRAWN BY: BPJ	DATE: MAR 3, 2009
		<b>DR - 2</b>

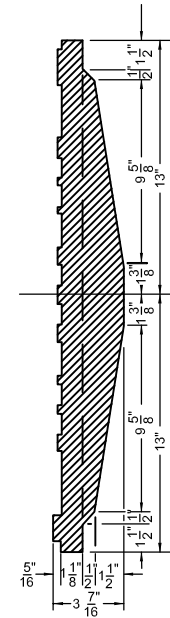
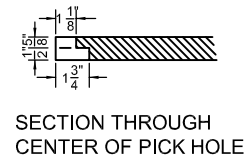
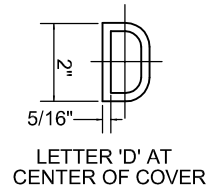
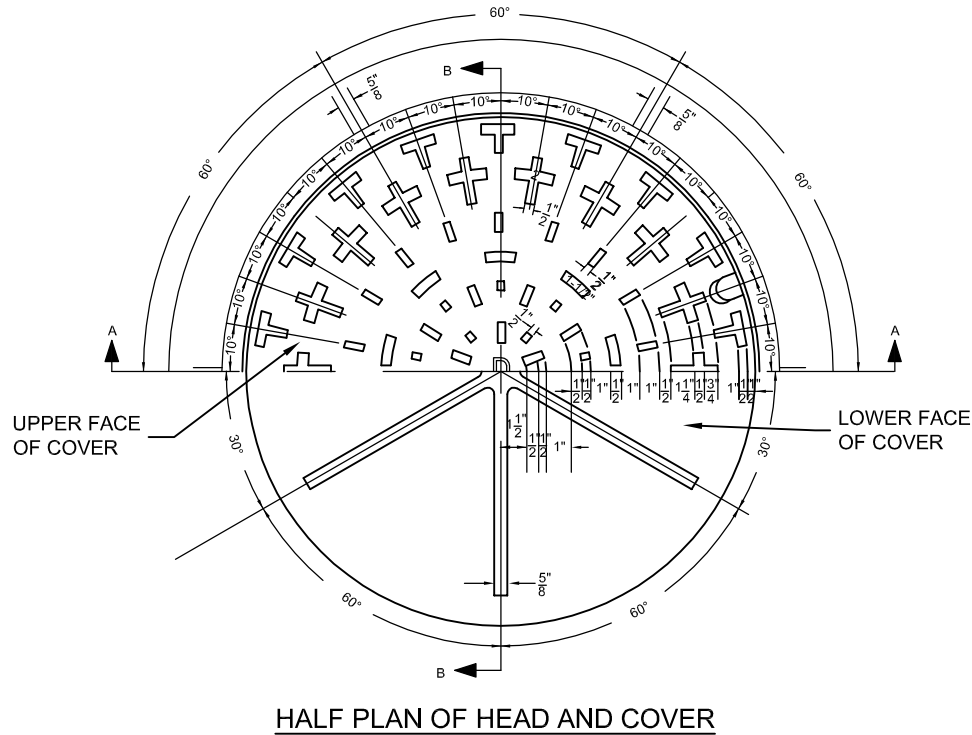

**NOTE:**  
A SHORT FRAME REQUIRES APPROVAL OF THE PUBLIC WORKS INSPECTOR.

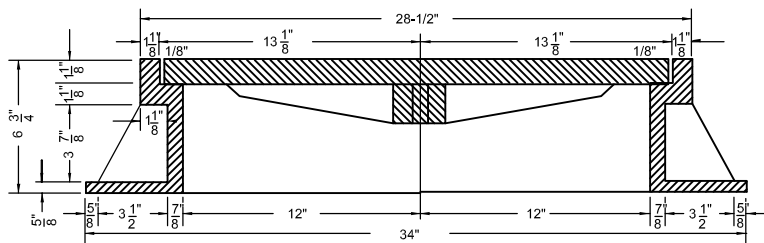

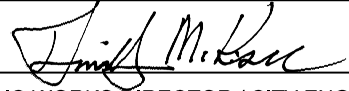
	PUBLIC WORKS DEPARTMENT ENGINEERING DIVISION	
	<b>STANDARD DRAINAGE MANHOLE FRAME &amp; COVER</b>	
APPROVED BY: 		
PUBLIC WORKS DIRECTOR / CITY ENGINEER		
SCALE: NONE	DRAWN BY: EAD	DATE: MAY 12, 2016
		<b>DR - 3</b>

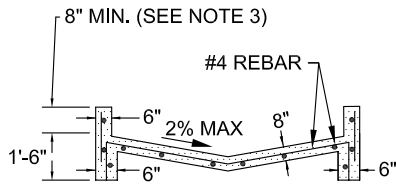

**SECTION A-A**

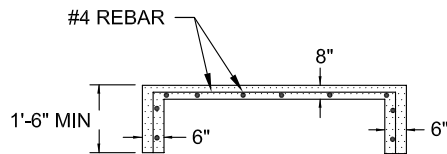

**SECTION B-B**

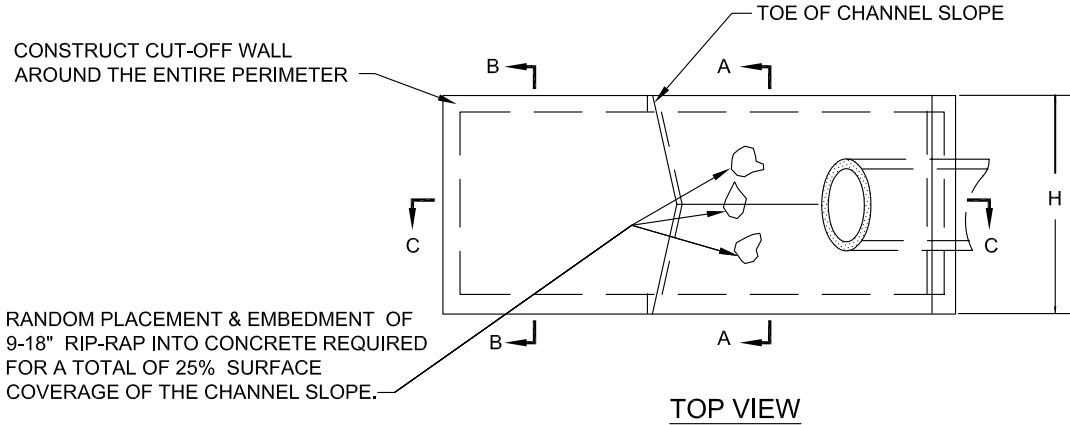

**TOP VIEW**

MITER CUT PIPE TO FIT FLUSH WITH SLOPE UNLESS INTEGRATED INTO A HEADWALL.

TIE & ANCHOR REBAR INTO HEADWALL IF A HEADWALL IS REQUIRED. IF NO HEADWALL, CONSTRUCT A REINFORCED COLLAR.

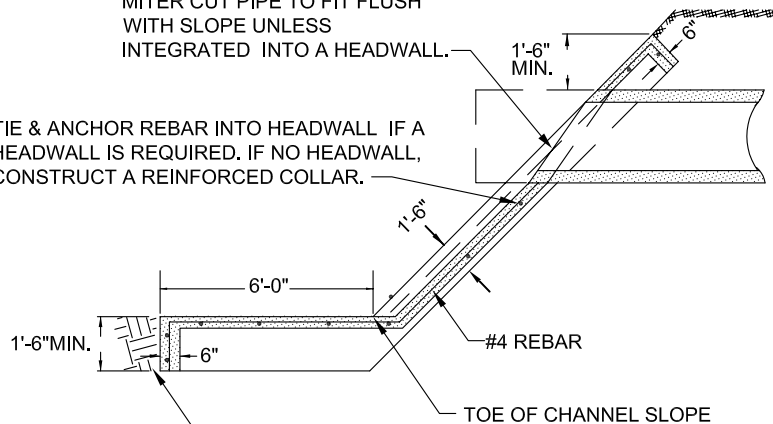

**SECTION C-C**

95% COMPACTION OF NATIVE SOIL LEVEL WITH FRONT AND SIDES.

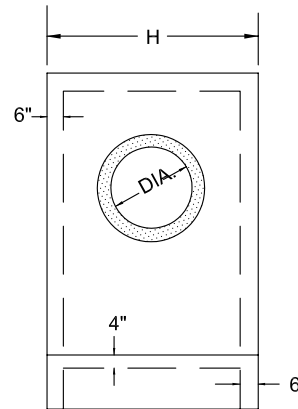

**FRONT VIEW**

**NOTES:**

1. EROSION CONTROL PIPE DISCHARGE TO BE INSTALLED AS NEEDED BASED UPON PIPE DIAMETER AND VELOCITY, AS REQUIRED BY THE CITY ENGINEER.
2. USE CLASS 'A' CONCRETE, 6 SACK AND COBBLES AS SPECIFIED.
3. #4 REBARS 12" O.C. EACH DIRECTION.
4. H= 4 x PIPE DIA. (6-FT MINIMUM).
5. WALL HEIGHT VARIES AS REQUIRED BY CUT SLOPE.
6. HYDROSEED ALL DISTURBED AREAS.

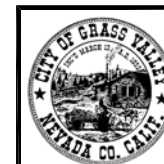

PUBLIC WORKS DEPARTMENT  
ENGINEERING DIVISION

**EROSION CONTROL  
PIPE DISCHARGE**

APPROVED BY:

*Jim McKeon*

PUBLIC WORKS DIRECTOR / CITY ENGINEER

SCALE:  
NONE

DRAWN BY:  
BPJ

DATE:  
MAR 3, 2009

**DR - 4**

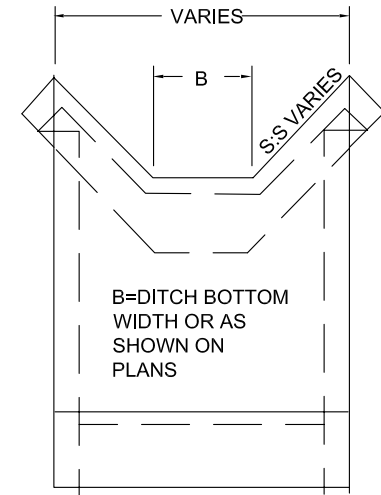
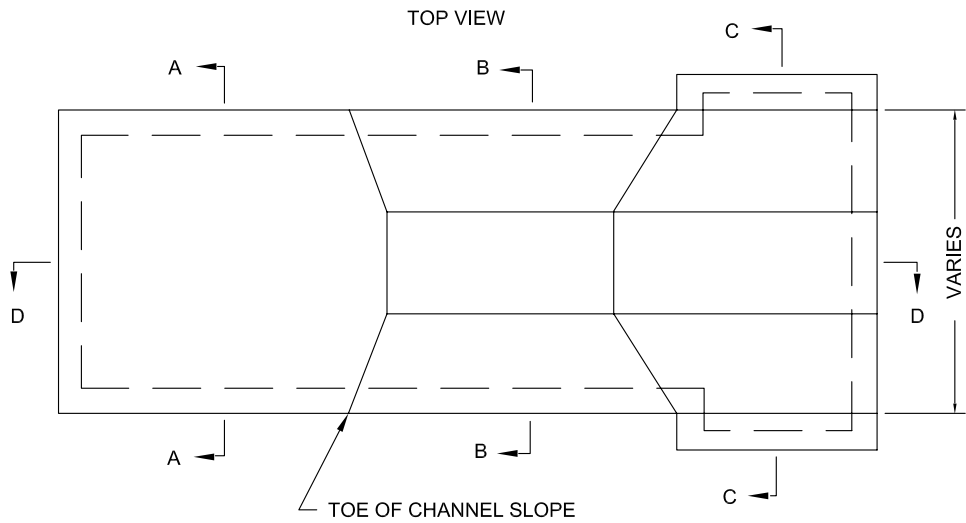

FRONT VIEW

**NOTES:**

1. USE CLASS "A" CONCRETE OR GROUDED COBBLES AS SPECIFIED.
2. 6X6X10 GA WIRE MESH THROUGHOUT CONCRETE
3. ON LINED CHANNELS APRON SHALL CONNECT TO SIDE LINING

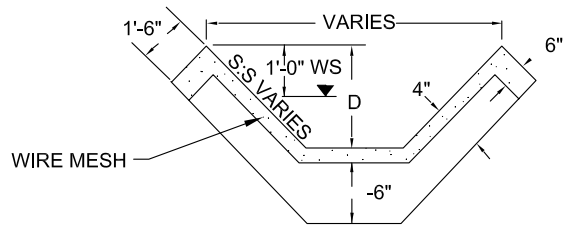

SECTION C-C

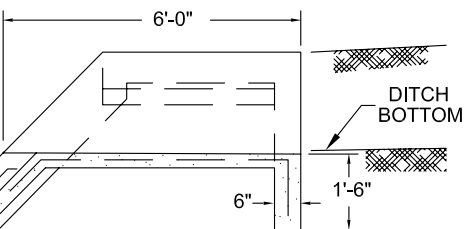

SECTION A-A

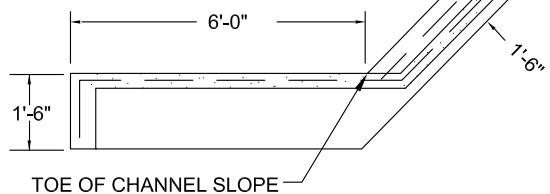

SECTION D-D

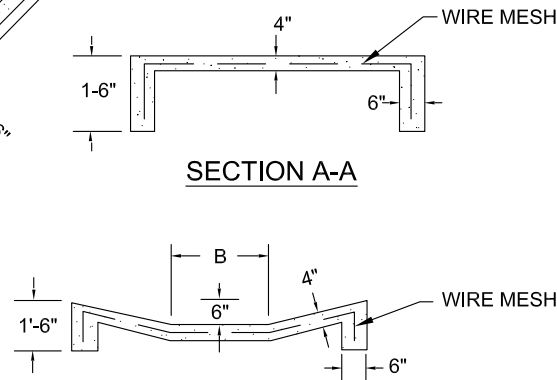

SECTION B-B

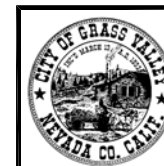

PUBLIC WORKS DEPARTMENT  
ENGINEERING DIVISION

**EROSION CONTROL  
DITCH DISCHARGE**

APPROVED BY:

*Jim McRae*

PUBLIC WORKS DIRECTOR / CITY ENGINEER

SCALE:  
NONE

DRAWN BY:  
BPJ

DATE:  
MAR 3, 2009

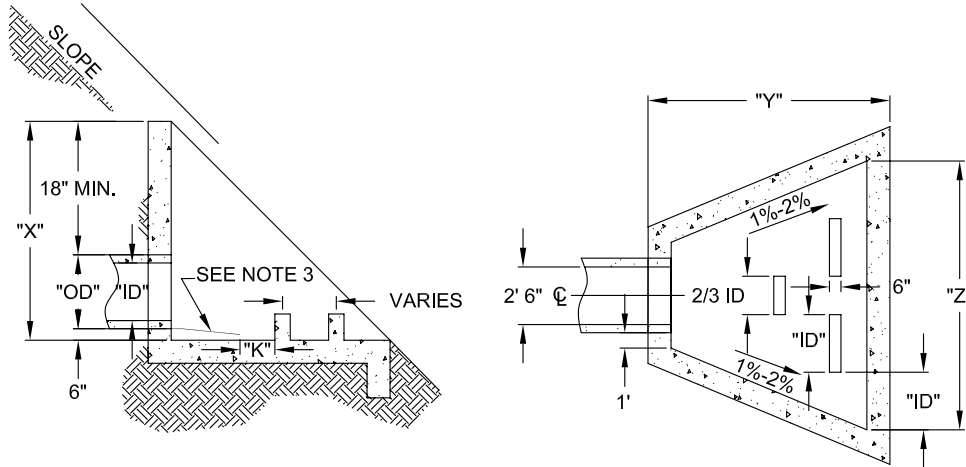

**DR - 5**

PIPE ID (INCHES)	PIPE OD (INCHES)	ACCESS CONTROL RACK		VARIABLE DIMINSIONS															
				SLOPE = 1:1				SLOPE = 1.5:1				SLOPE = 2:1				SLOPE = 3:1			
				W	H	X	Y	Z	K	X	Y	Z	K	X	Y	Z	K	X	Y
12	16.5	12	12	4'-6"	4'-6"	4'-8"	6"	3'-0"	4'-6"	4'-8"	6"	2'-10"	5'-9"	4'-8"	1'-2"	2'-10"	8'-8"	4'-8"	2'-6"
15	19.5	15	15	5'-0"	5'-0"	5'-10"	6"	3'-4"	5'-0"	5'-10"	6"	3'-2"	6'-3"	5'-10"	1'-2"	3'-2"	9'-4"	5'-10"	2'-8"
18	23	18	18	5'-6"	5'-6"	7'-0"	6"	3'-8"	5'-6"	7'-0"	6"	3'-6"	6'-8"	7'-0"	1'-2"	3'-6"	10'-3"	7'-0"	2'-10"
21	27	21	21	6'-0"	6'-0"	8'-2"	6"	4'-0"	6'-0"	8'-2"	6"	3'-9"	7'-6"	8'-2"	1'-3"	3'-9"	11'-3"	8'-2"	3'-2"
24	31.5	24	24	6'-6"	6'-6"	9'-4"	6"	4'-4"	6'-6"	9'-4"	6"	4'-2"	8'-3"	9'-4"	1'-4"	4'-2"	12'-4"	9'-4"	3'-5"
27	35	27	27	7'-0"	7'-0"	10'-6"	6"	4'-8"	7'-0"	10'-6"	6"	4'-9"	8'-10"	10'-6"	1'-5"	4'-9"	13'-3"	10'-6"	3'-8"
30	38.5	30	30	7'-6"	7'-6"	11'-8"	6"	5'-0"	7'-6"	11'-8"	6"	5'-3"	9'-6"	11'-8"	1'-6"	5'-3"	14'-2"	11'-8"	3'-10"
36	45.5	36	36	8'-5"	8'-5"	14'-0"	6"	5'-8"	8'-5"	14'-0"	6"	8'-5"	10'-7"	14'-0"	1'-7"	8'-5"	15'-10"	14'-0"	4'-2"
42	52.5	42	42	9'-6"	9'-6"	16'-4"	6"	6'-4"	9'-6"	16'-4"	6"	5'-10"	11'-9"	16'-4"	1'-8"	5'-10"	17'-8"	16'-4"	4'-6"
58	59	48	48	10'-6"	10'-6"	18'-8"	6"	7'-0"	10'-6"	18'-8"	6"	6'-6"	12'-10"	18'-8"	1'-8"	6'-6"	19'-3"	18'-8"	4'-10"
54	66	60	60	11'-6"	11'-6"	21'-0"	6"	7'-8"	11'-6"	21'-0"	6"	7'-0"	14'-0"	21'-0"	1'-9"	7'-0"	21'-0"	21'-0"	5'-3"
60	72	60	60	12'-6"	12'-6"	23'-4"	6"	8'-4"	12'-6"	23'-4"	6"	7'-6"	15'-0"	23'-4"	1'-9"	7'-6"	22'-6"	23'-4"	5'-6"
66	78	66	66	13'-6"	13'-6"	25'-8"	6"	9'-0"	13'-6"	25'-8"	6"	8'-0"	16'-0"	25'-8"	1'-9"	8'-0"	24'-0"	25'-8"	5'-9"
72	84	72	72	14'-6"	14'-6"	28'-0"	6"	9'-8"	14'-6"	28'-0"	6"	8'-6"	17'-0"	28'-0"	1'-9"	8'-6"	25'-6"	28'-0"	6'-0"



**NOTES:**

1. STRUCTURAL CALCULATIONS SHALL BE SUBMITTED FOR HEADWALL.
2. ALL CONCRETE TO BE CLASS "A" 6-SACK.
3. REFER TO "PIPE INLET/OUTLET STRUCTURE AND TRASH RACK" DETAIL FOR ACCESS CONTROL RACK.

	PUBLIC WORKS DEPARTMENT ENGINEERING DIVISION	
	<b>HEADWALL</b>	
APPROVED BY: 		
PUBLIC WORKS DIRECTOR / CITY ENGINEER		
SCALE: NONE	DRAWN BY: BPJ	DATE: MAR 3, 2009
		<b>DR - 6</b>

## DIMENSIONS & REINFORCING

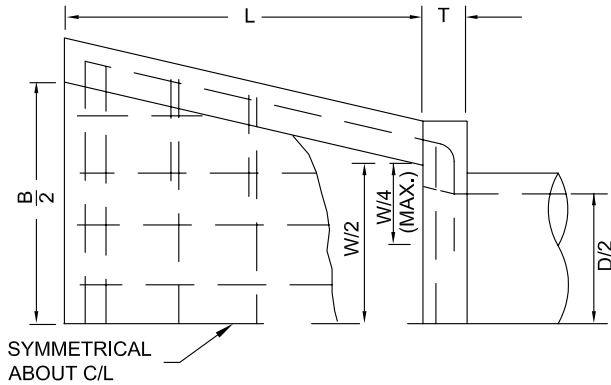

D	W	B	L	T	ALL REINFORCING
33"	3'- 5"	5'- 3"	4'- 0"	6"	# 5 @ 12"
36"	3'- 8"	5'- 8"	4'- 2"	6"	# 5 @ 12"
42"	4'- 4"	6'- 4"	4'- 8"	6"	# 5 @ 12"
48"	4'-10"	7'- 2"	5'- 2"	8"	# 6 @ 12"
54"	5'- 4"	8'- 0"	6'- 0"	8"	# 6 @ 12"
60"	6'- 0"	8'-10"	6'- 6"	8"	# 6 @ 12"

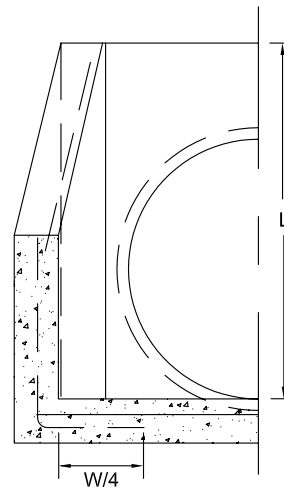
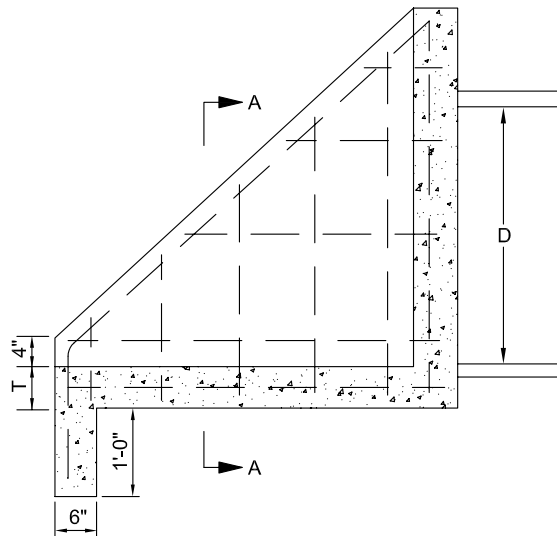

### NOTES:

1. "B" MAY BE REDUCED IF REQUIRED BY CHANNEL DIMENSIONS
2. REINFORCING BAR SPACING SHOWN IS MAXIMUM SPACING.
3. USE CLASS 'A' CONCRETE, 6 SACK.
4. SEE CST, DR-13 FOR TRASH RACK



PUBLIC WORKS DEPARTMENT  
ENGINEERING DIVISION

### PIPE INLET STRUCTURE

APPROVED BY:

*Jim McRae*

PUBLIC WORKS DIRECTOR / CITY ENGINEER

SCALE:  
NONE

DRAWN BY:  
BPJ

DATE:  
MAR 3, 2009

DR - 7

**NOTE:**

ALL REINFORCING STEEL SHALL HAVE 2" EMBEDMENT EXCEPT AS NOTED

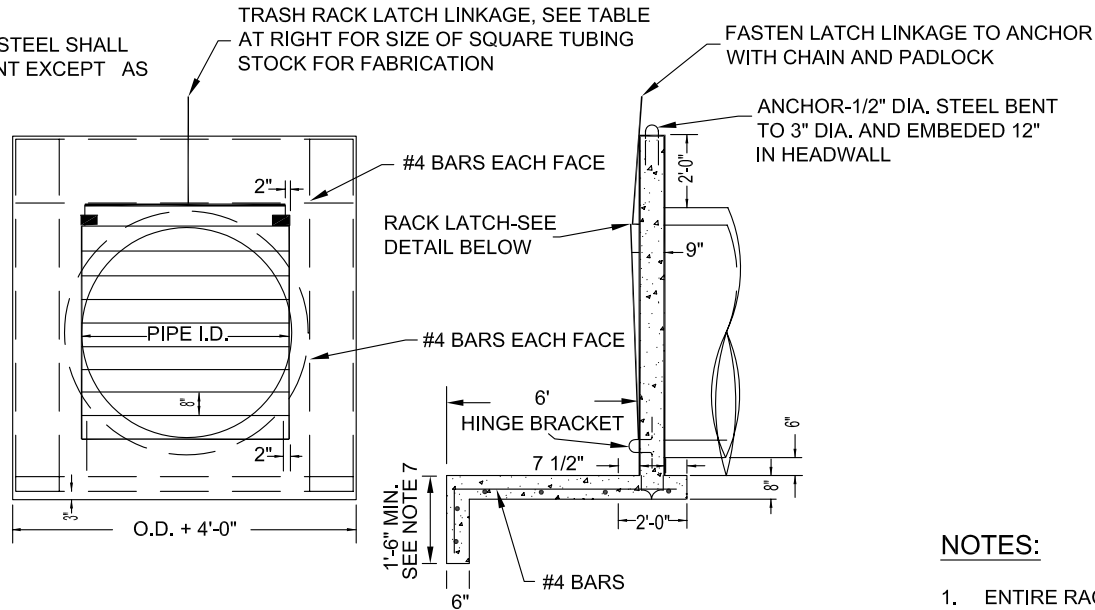

PIPE SIZE	RACK BAR SIZE	LATCH PLATE THICKNESS	LATCH LINKAGE SIZE
21"	#4	1/4"	1", .095" THICK
24"	"	"	"
27"	#5	"	"
30"	"	3/8"	"
33"	#6	"	"
36"	"	"	1", .133" THICK
42"	#7	"	"
48"	"	1/2"	"
54"	"	"	"
60"	#8	"	"
66"	"	"	"
72"	"	"	"
84"	"	"	"

**NOTES:**

1. ENTIRE RACK TO BE WELDED REINFORCING STEEL OR ROUND BARS OF EQUAL DIA. WITH HORIZONTAL BARS BEING 8" CENTER TO CENTER.
2. USE CLASS "A" CONCRETE, 6 SACK.
3. ROOM SHALL BE PROVIDED DOWNSTREAM TO LAY RACK FLAT.
4. FASTEN LATCH BRACKET TO HEADWALL WITH 1/2" X 6" BOLTS WITH HEX NUTS, OR 1/2" EXPANSION BOLTS.
5. WHEN RACK IS IN THE CLOSED POSITION, THE BOTTOM RACK BAR SHALL BE TIGHT AGAINST THE TOP OF THE HINGE BRACKET SO THAT THE RACK CANNOT BE LIFTED OFF THE LATCH.
6. FABRICATE HINGE BRACKET FROM #4 RE-BAR.
7. CUTOFF WALL NOT REQUIRED IF HEADWALL IS TIED TO DETAIL DR-11.
8. SITE CONDITIONS MAY DICTATE THE USE OF A MODIFIED DESIGN. ALL VARIATIONS TO BE APPROVED BY THE CITY ENGINEER.

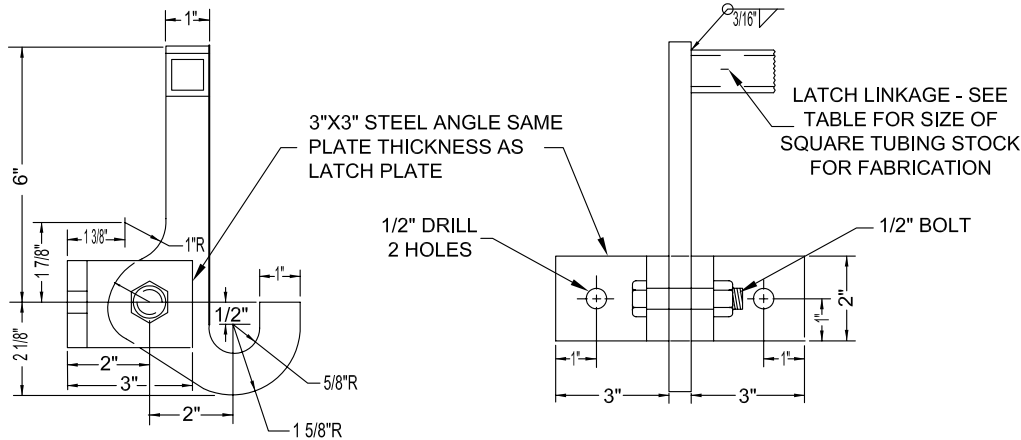

**NOTE:**

FABRICATE LATCH FROM STEEL PLATE, THICKNESS SHOWN IN TABLE



PUBLIC WORKS DEPARTMENT  
ENGINEERING DIVISION

**PIPE INLET/OUTLET STRUCTURE  
AND TRASH RACK**

APPROVED BY:

*Jim McRae*

PUBLIC WORKS DIRECTOR / CITY ENGINEER

SCALE:  
NONE

DRAWN BY:  
BPJ

DATE:  
MAR 3, 2009

**DR - 8**



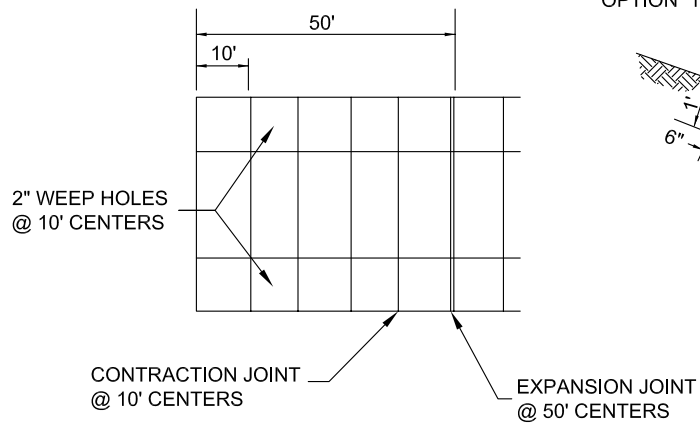

PLAN

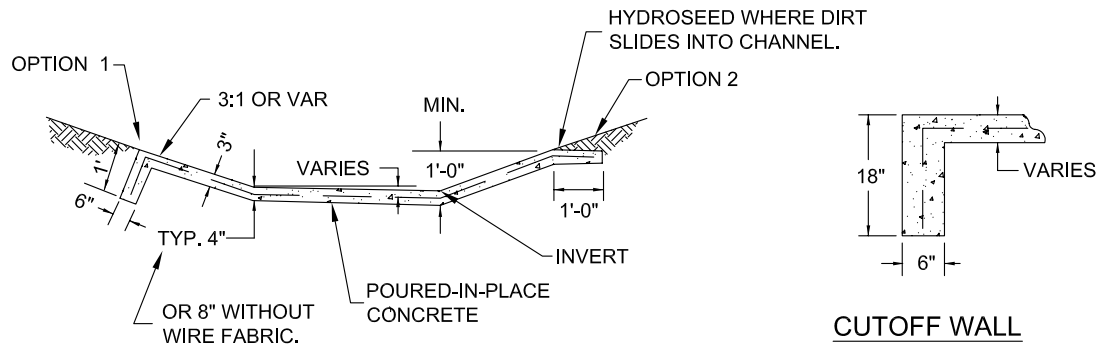

ALTERNATE "A"

CUTOFF WALL

TO BE PLACED ALONG ENTIRE END OF LINED SECTION AT BEGINNING AND AT END OF LINING

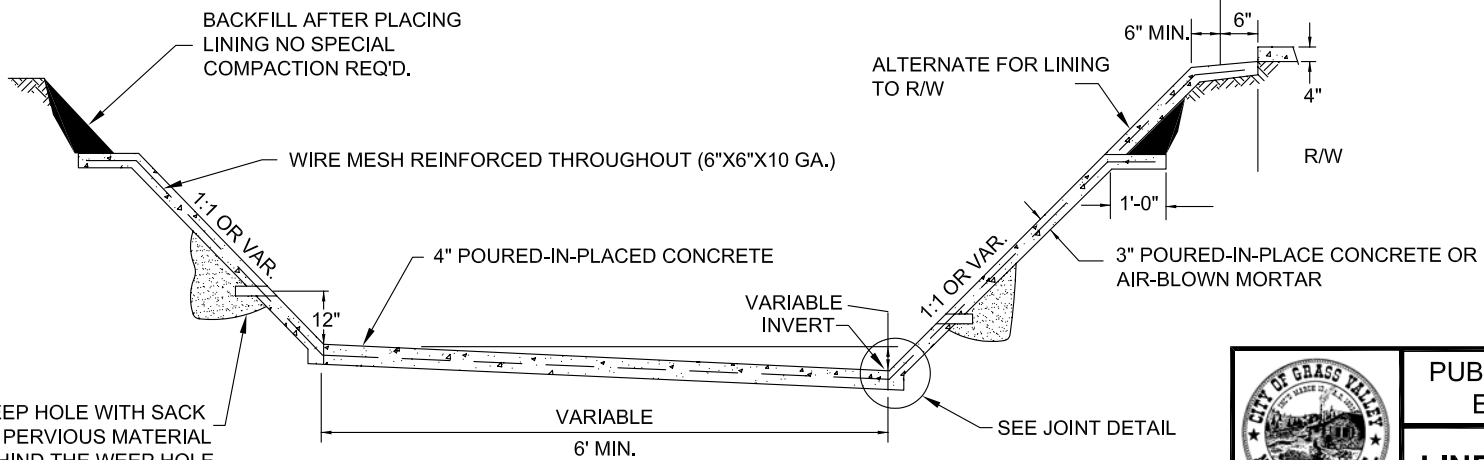

SECTION

JOINT DETAIL

WEEP HOLE WITH SACK OF PERVIOUS MATERIAL BEHIND THE WEEP HOLE (1 C.F. MIN.) HOLE TO BE 2" DIAMETER PIPE, CUT TO FIT

NOTE: SEE SECTION 101-8 FOR MATERIALS

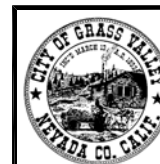

PUBLIC WORKS DEPARTMENT  
ENGINEERING DIVISION

**LINED CHANNEL SECTION**

APPROVED BY:

*Jim McRae*

PUBLIC WORKS DIRECTOR / CITY ENGINEER

SCALE:  
NONE

DRAWN BY:  
BPJ

DATE:  
MAR 3, 2009

**DR - 9**

MAXIMUM TRENCH DEPTH MEASURED SURFACE TO BOTTOM OF TRENCH IN FEET								
DIAMETER	REINFORCED CONCRETE PIPE -CLASS-					CAST IN PLACE		
	I	II	III	IV	V			
10	NOT PERMITTED					NO LIMIT		
12		8	12	30				
15		10	15	35				
18		11	16	38				
21		12	17	39				
24		12	18	39				
27		13	19	39				
30		14	19	38				
33		14	20	38				
36		13	17	27	69			
42		14	18	29	62			
48		15	19	30	60			
54		16	20	31	58			
60		14	16	21	31		57	45
66		15	17	22	32		56	35
72	15	18	23	33	56	30		

MINIMUM COVER MEASURED SURFACE TO TOP OF PIPE IN INCHES			
TYPE	CLASS	MIN. COVER	
		STREET	OFF ST.
REINFORCED CONCRETE	I	27	12
	II	24	12
	III	18	12
	IV	12	12
	V	12	12
CAST PLACE CONC. PIPE	—	24	12
CORRUGATED DUAL WALL HDPE PIPE		36	24

**NOTES:**

ALL DEPTHS SHOWN ARE FLEXIBLE PAVEMENT AND TRENCH WIDTH EQUAL TO O.D. OF PIPE PLUS 16" FOR PIPE 33" AND SMALLER IN INSIDE DIAMETER. TRENCH WIDTH EQUALS O.D. OF PIPE PLUS 24" FOR PIPE 36" AND LARGER IN INSIDE DIAMETER. TRENCH WIDTH MEASURED AT TOP OF PIPE.

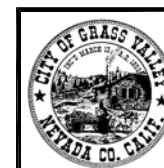

PUBLIC WORKS DEPARTMENT  
ENGINEERING DIVISION

**TRENCH DEPTH & MINIMUM  
COVER REQUIREMENTS**

APPROVED BY:

*Jim McRae*

PUBLIC WORKS DIRECTOR / CITY ENGINEER

SCALE:  
NONE

DRAWN BY:  
BPJ

DATE:  
MAR 3, 2009

**DR-10**